

MC74C912

6-Digit BCD Display Controller/Driver

General Description

The MC74C912 display controllers are interface elements, with memory, that drive a 6-digit, 8-segment LED display. The display controllers receive data information through 5 data inputs A, B, C, D and DP, and digit information through 3 address inputs K1, K2 and K3.

The input data is written into the register selected by the address information when CHIP ENABLE, (CE), and WRITE ENABLE, (WE), are LOW and is latched when either CE or WE return HIGH. Data hold time is not required. A self-contained internal oscillator sequentially presents the stored data to a decoder where 4 data bits control the format of the displayed character and 1 bit controls the decimal point. The internal oscillator is controlled by a control input labeled OSCILLATOR ENABLE, (OSE), which is tied LOW in normal operation. A high level at OSE prevents automatic refresh of the display. The 7-segment plus decimal point output information directly drives an LED display through high drive (100 Ma typ.) output drivers. The drivers are active when the control pin labeled SEGMENT OUTPUT ENABLE, (SOE), is LOW and go into 3-STATE when SOE is HIGH. This feature allows for duty cycle brightness control and for disabling the output drivers for power conservation.

The MC74C912 segment decoder converts BCD data into 7-segment format.

All inputs are TTL compatible and do not clamp to the VCC supply.

Features

- Direct segment drive (100 mA typ.) 3-STATE
- 6 registers addressed like RAM
- Internal oscillator and scanning circuit
- Direct base drive to digit transistor (20 mA typ.)
- Internal segment decoder
- TTL compatible inputs

Ordering Code:

Order Number	Package Number	Package Description
MC74C912	N28B	28-Lead Plastic Dual-In-Line Package (PDIP), JEDEC MS-010, 0.600" Wide

Connection Diagram

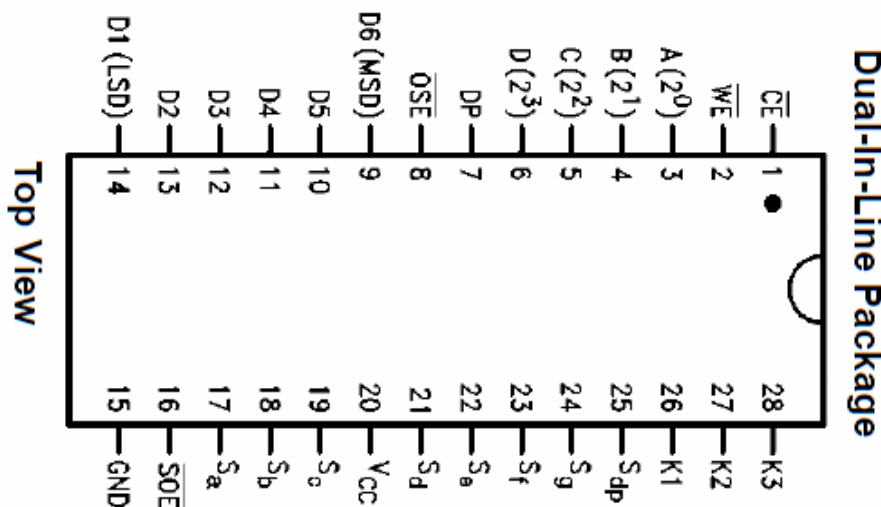

Truth Tables

Input Control

$\overline{\text{CE}}$	Digit Address			$\overline{\text{WE}}$	Operation
	K3	K2	K1		
0	0	0	0	0	Write Digit 1
0	0	0	0	1	Latch Digit 1
0	0	0	1	0	Write Digit 2
0	0	0	1	1	Latch Digit 2
0	0	1	0	0	Write Digit 3
0	0	1	0	1	Latch Digit 3
0	0	1	1	0	Write Digit 4
0	0	1	1	1	Latch Digit 4
0	1	0	0	0	Write Digit 5
0	1	0	0	1	Latch Digit 5
0	1	0	1	0	Write Digit 6
0	1	0	1	1	Latch Digit 6
0	1	1	0	0	Write Null Digit
0	1	1	0	1	Latch Null Digit
0	1	1	1	0	Write Null Digit
0	1	1	1	1	Latch Null Digit
1	X	X	X	X	Disable Writing

X = Don't Care

Output Control

$\overline{\text{SOE}}$	$\overline{\text{OSE}}$	Operation
0	0	Refresh Display
0	1	Stop Oscillator (Note 1)
1	0	Disable Segment Outputs
1	1	Standby Mode

Note 1: Segment drive may exceed maximum display dissipation.

MC74C912

Functional Description

Character Font

MM74C912	Hi-Z	0	1	2	3	4	5	6	7	8	9	o	°	-	·	.
Input A 2 ⁰	X	0	1	0	1	0	0	0	1	0	1	0	1	0	1	1
Data B 2 ¹	X	0	0	1	1	0	1	1	1	0	0	1	1	0	0	1
C 2 ²	X	0	0	0	0	1	1	1	1	0	0	0	0	1	1	1
D 2 ³	X	0	0	0	0	0	0	0	0	1	1	1	1	1	1	1
DP	X	0	0	0	0	0	0	0	0	0	0	0	0	0	0	1
OUTPUT ENABLE \overline{SOE}	1	0	0	0	0	0	0	0	0	0	0	0	0	0	0	0

Segment Identification

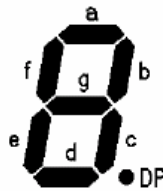

The MC74C912 display controller is manufactured using metal gate CMOS technology. A single 5V 74 series TTL supply can be used for power and should be bypassed at the VCC pin.

All inputs are TTL compatible; the segment outputs drive the LED display directly through current limiting resistors. The digit outputs are designed to directly drive the base of a grounded emitter digit transistor without the need of a Darlington configuration.

As seen in the block diagram, these display controllers contain six 5-bit registers; any one of which may be randomly written. The internal multiplexer scans the registers and refreshes the display. This combination of write only memory and self-scan display makes the display controller a “refreshing experience” for an over-burdened microprocessor

Block Diagram

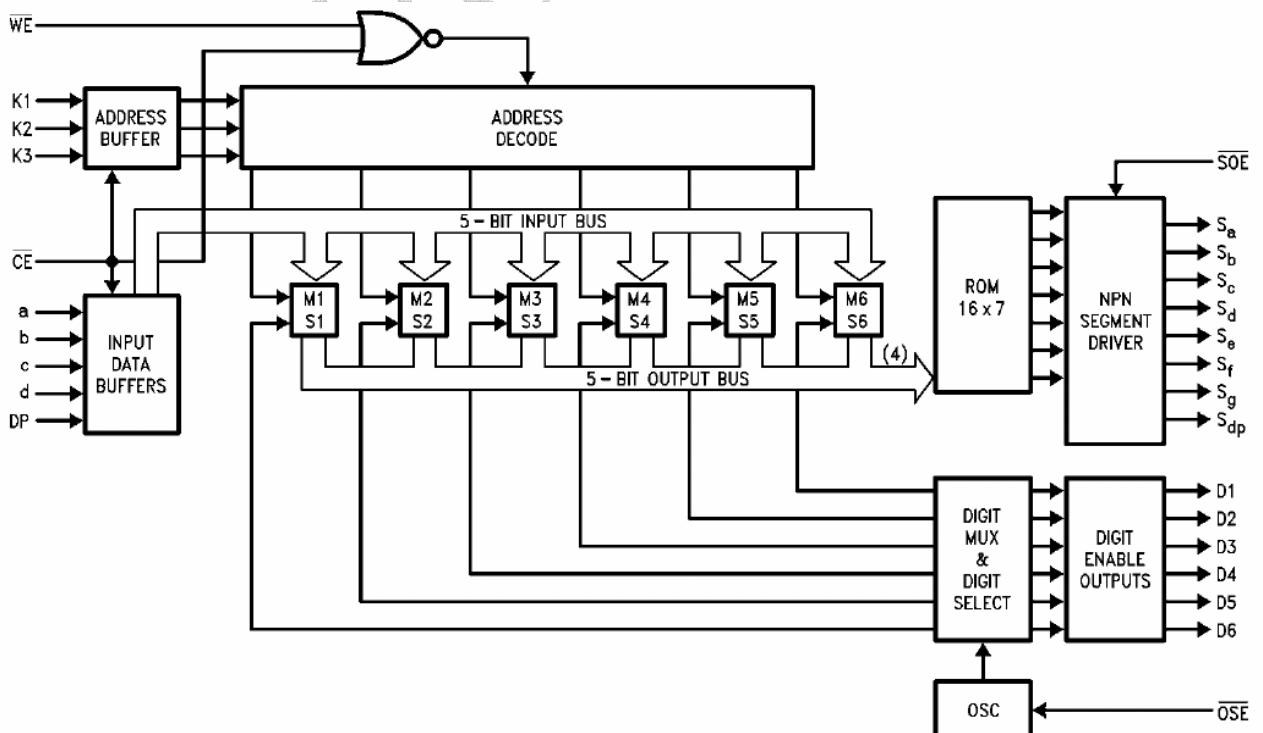

Absolute Maximum Ratings(Note 2) (Note 3)

Voltage at Any Pin	
Except Inputs	-0.3V to VCC + 0.3V
Voltage at Any Input	-0.3V to +15V
Operating Temperature	
Range (TA)	-40°C to +85°C
Storage Temperature	
Range (TS)	-65°C to +150°C
Power Dissipation (PD)	Refer to PD MAX vs TA Graph
Operating VCC Range	3V to 6V
Absolute Maximum (VCC)	6.5V
Lead Temperature	
(Soldering, 10 seconds)	260°C

Note 2: "Absolute Maximum Ratings" are those values beyond which the safety of the device cannot be guaranteed. Except for "Operating Range" they are not meant to imply that the device should be operated at these limits. The table of "Electrical Characteristics" provides conditions for actual device operation.

Note 3: All voltages reference to ground.

DC Electrical Characteristics

Min/Max limits apply at 40°C ≤ TJ ≤ 85°C, unless otherwise noted

Symbol	Parameter	Conditions	Min	Typ	Max	Units
CMOS TO CMOS						
V _{IN(1)}	Logical "1" Input Voltage	V _{CC} = 5V	3.0			V
V _{IN(0)}	Logical "0" Input Voltage	V _{CC} = 5V			1.5	V
I _{IN(1)}	Logical "1" Input Current	V _{CC} = 5V, V _{IN} = 15V		0.005	1.0	μA
I _{IN(0)}	Logical "0" Input Current	V _{CC} = 5V, V _{IN} = 0V	-1.0	-0.005		μA
I _{CC}	Supply Current	V _{CC} = 5V, Outputs Open		0.5	2	mA
I _{OUT}	3-STATE Output Current	V _{CC} = 5V, V _O = 5V V _{CC} = 5V, V _O = 0V	-10	0.03 -0.03	10	μA
CMOS/LPTTL INTERFACE						
V _{IN(1)}	Logical "1" Input Voltage	V _{CC} = 4.75V	V _{CC} - 2.0			V
V _{IN(0)}	Logical "0" Input Voltage	V _{CC} = 4.75V			0.8	V
OUTPUT DRIVE						
I _{SH}	High Level Segment Current	V _{CC} = 5V, V _O = 3.4V T _J = 25°C T _J = 100°C	-60 -40	-100 -60		mA mA
I _{DH}	High Level Digit Current	V _{CC} = 5V, V _O = 1V T _J = 25°C T _J = 100°C	-10 -7	-20 -15		mA mA
V _{OUT(1)}	Logical "1" Output Voltage Any Digit	V _{CC} = 5V, I _O = -360μA	4.6			V
V _{OUT(0)}	Logical "0" Output Voltage Any Digit	V _{CC} = 5V, I _O = 360μA			0.4	V
θ _{JA}	Thermal Resistance	(Note 4)		100		°C/W

Note 4: qJA measured in free air with device soldered into printed circuit board.

AC Electrical Characteristics (Note 5)

VCC = 5V, tr = tf = 20 ns, CL = 50 pF

Symbol	Parameter	Conditions	Min	Typ	Max	Units
t _{CW}	Chip Enable to Write Enable Setup Time	T _J = 25°C	35	15		ns
		T _J = 125°C	50	20		ns
t _{AW}	Address to Write Enable Setup Time	T _J = 25°C	35	15		ns
		T _J = 125°C	50	20		ns
t _{WW}	Write Enable Width	T _J = 25°C	400	225		ns
		T _J = 125°C	450	250		ns
t _{DW}	Data to Write Enable Setup Time	T _J = 25°C	390	225		ns
		T _J = 125°C	430	250		ns
t _{WD}	Write Enable to Data Hold Time	T _J = 25°C	0	-10		ns
		T _J = 125°C	0	-15		ns
t _{WA}	Write Enable to Address Hold Time	T _J = 25°C	0	-10		ns
		T _J = 125°C	0	-15		ns
t _{WC}	Write Enable to Chip Enable Hold Time	T _J = 25°C	50	30		ns
		T _J = 125°C	75	40		ns
t _{IH} , t _{OH}	Logical "1", Logical "0" Levels into 3-STATE	R _L = 10k, T _J = 25°C		275	500	ns
		C _L = 10 pF, T _J = 125°C		325	600	ns
t _{HI} , t _{HO}	3-STATE to Logical "1" to Logical "0" Level	R _L = 10k, T _J = 25°C		325	600	ns
		C _L = 50 pF, T _J = 125°C		375	700	ns
t _{IB}	Interdigit Blanking Time	T _J = 25°C	5	10		μs
		T _J = 125°C	10	20		μs
f _{MUX}	Multiplex Scan Frequency	T _J = 25°C		350		Hz
		T _J = 125°C		250		Hz
C _{IN}	Input Capacitance	(Note 6)		5	7.5	pF
C _{OUT}	3-STATE Output Capacitance	(Note 6)		30	50	pF

Note 5: AC Parameters are guaranteed by DC correlated testing.**Note 6:** Capacitance is guaranteed by periodic testing.

MC74C912

Switching Time Waveforms

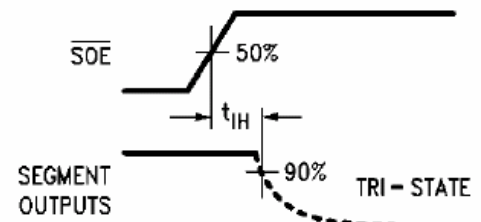
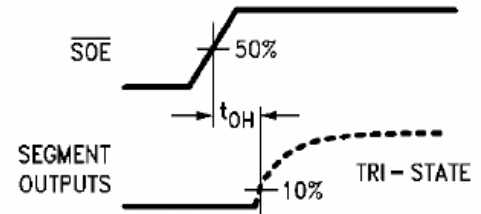
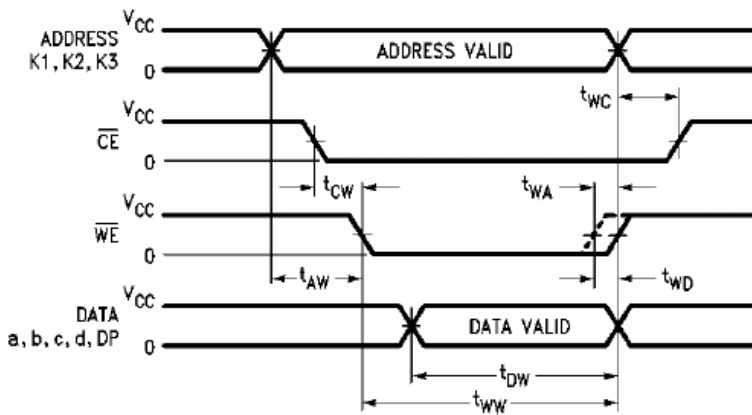

Multiplexing Output Waveforms

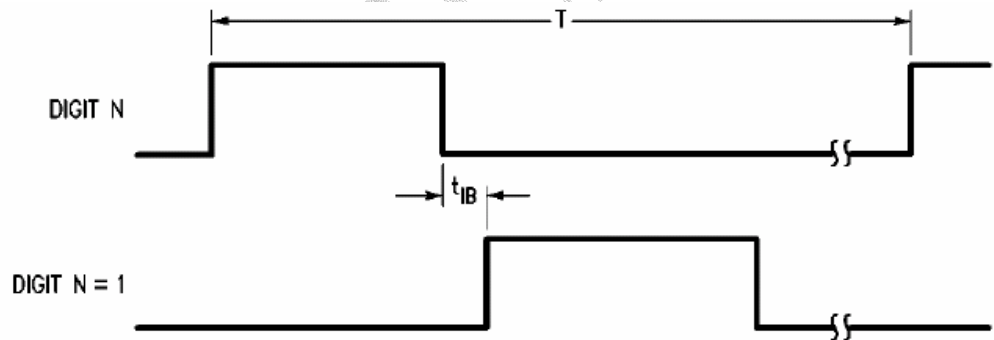

$$T = 1/f_{MUX}$$

MICROCELL

MC74C912

Typical Performance Characteristics

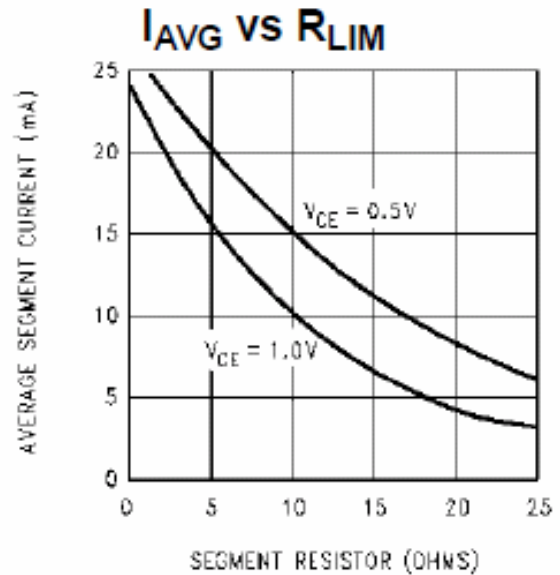
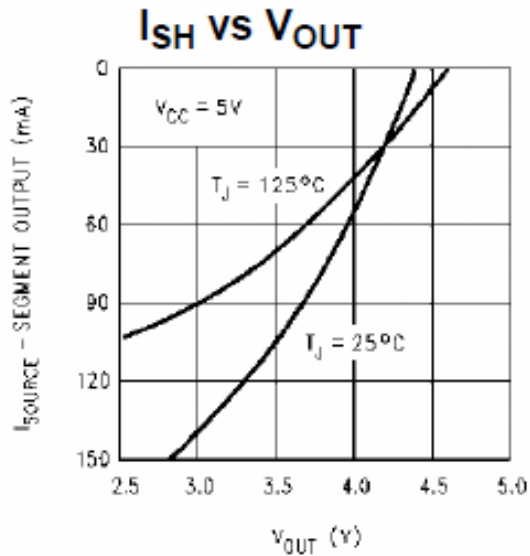

Segment outputs if shorted to ground will exceed maximum power dissipation of the device. V_{CE} is the saturation voltage of the digit drive transistor.

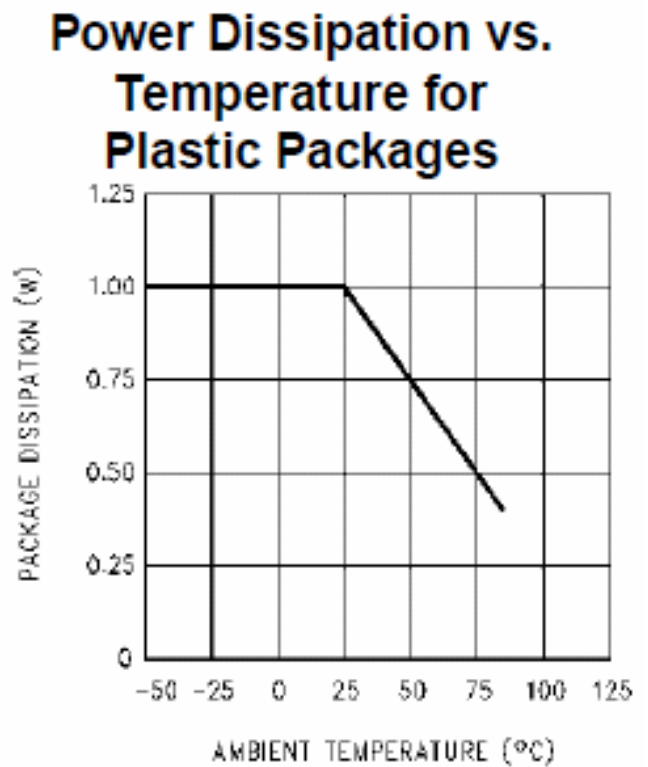
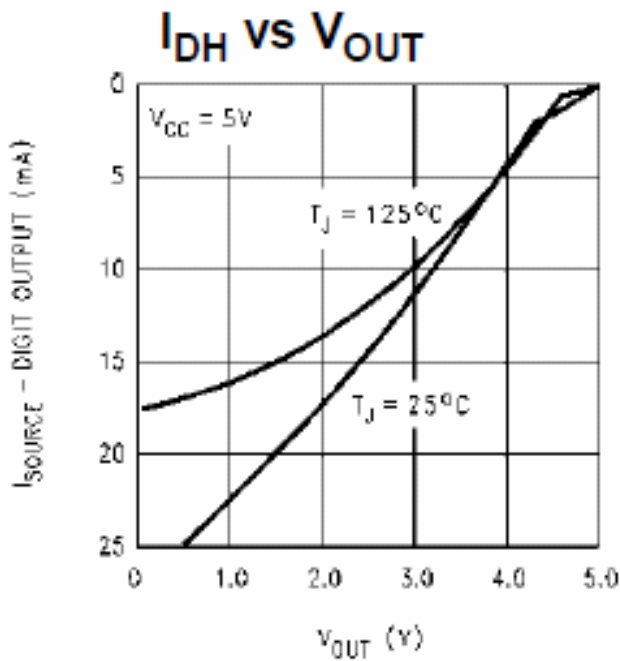

MC74C912

MC74C912 Typical Applications

Digit Output Structure

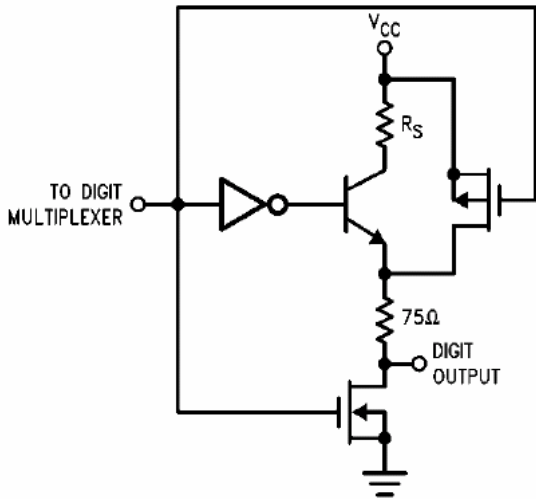

Segment Output Structure

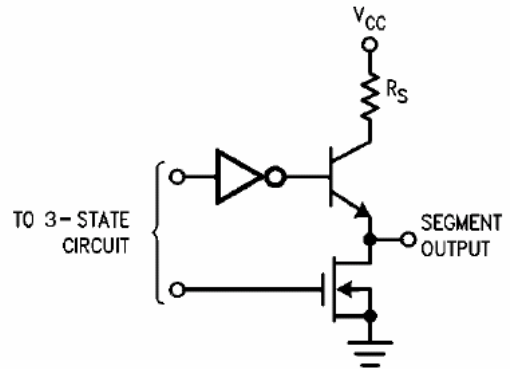

Input Protection

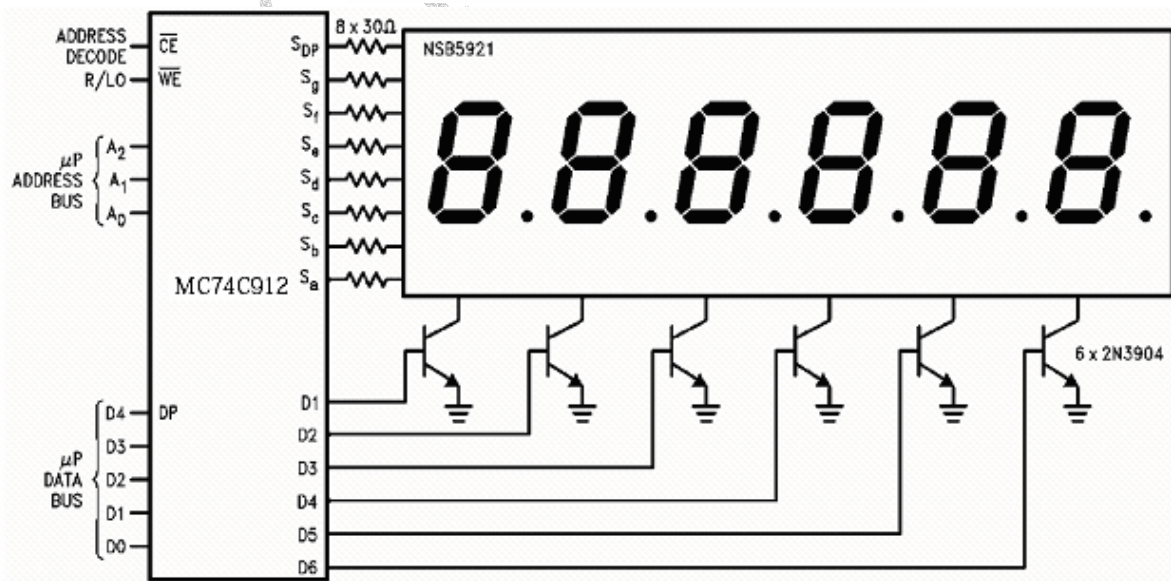
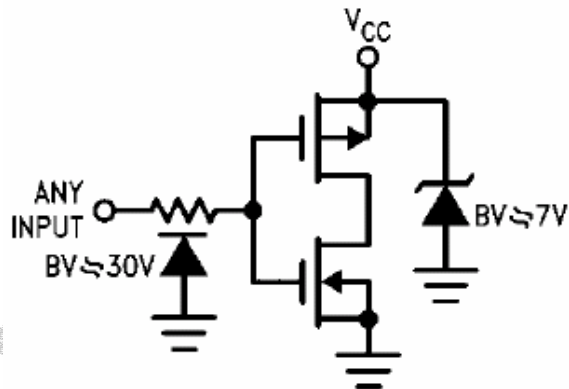

MC74C912

Physical Dimensions inches (millimeters) unless otherwise noted

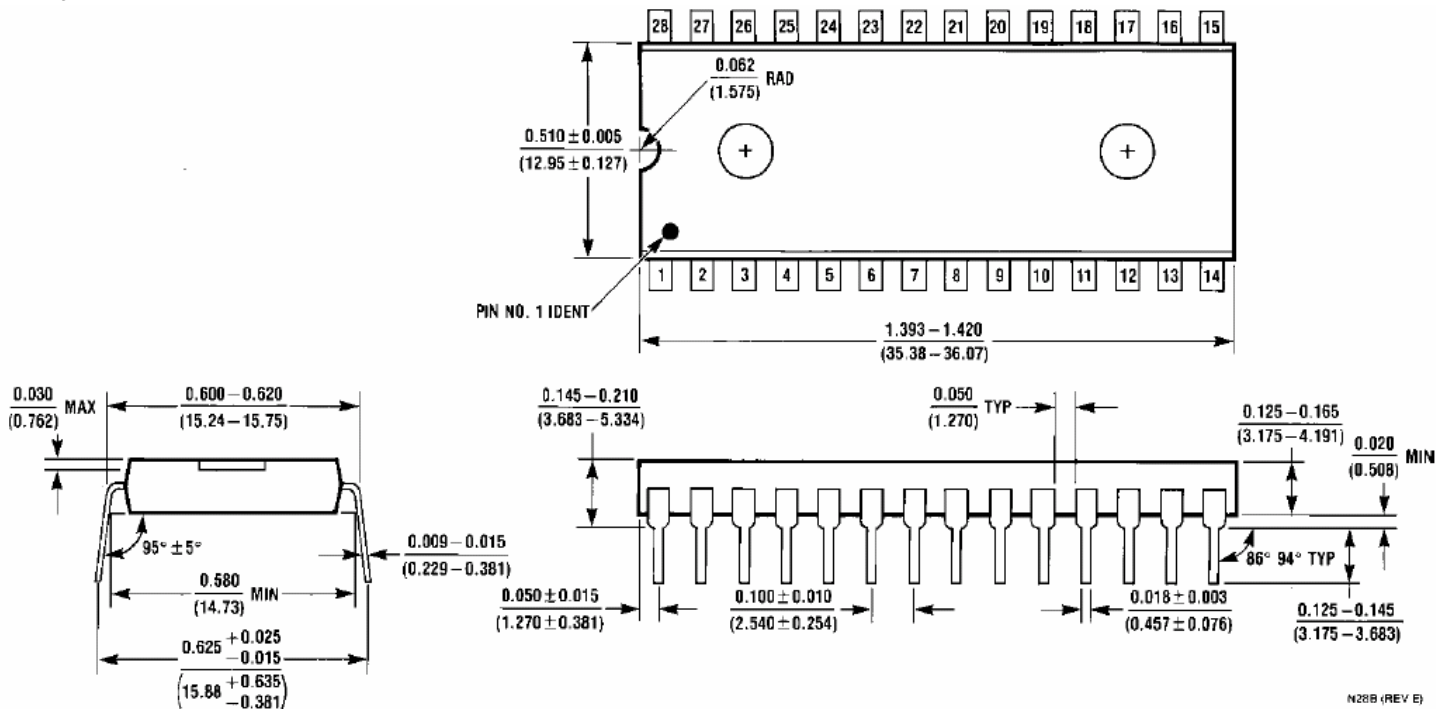

**28-Lead Plastic Dual-In-Line Package (PDIP), JEDEC MS-010, 0.600" Wide
Package Number N28B**

MICROCELL