

 **MC2206**
**FEATURES**

- \_ Low-Sine Wave Distortion, 0.5%, Typical
- \_ Excellent Temperature Stability, 20ppm/°C, Typ.
- \_ Wide Sweep Range, 2000:1, Typical
- \_ Low-Supply Sensitivity, 0.01%V, Typ.
- \_ Linear Amplitude Modulation
- \_ TTL Compatible FSK Controls
- \_ Wide Supply Range, 10V to 26V
- \_ Adjustable Duty Cycle, 1% TO 99%

**APPLICATIONS**

- \_ Waveform Generation
- \_ Sweep Generation
- \_ AM/FM Generation
- \_ V/F Conversion
- \_ FSK Generation
- \_ Phase-Locked Loops (VCO)

**GENERAL DESCRIPTION**

The MC2206 is a monolithic function generator integrated circuit capable of producing high quality sine, square, triangle, ramp, and pulse waveforms of high-stability and accuracy. The output waveforms can be both amplitude and frequency modulated by an external voltage. Frequency of operation can be selected externally over a range of 0.01Hz to more than 1MHz. The circuit is ideally suited for communications, instrumentation, and function generator applications requiring sinusoidal tone, AM, FM, or FSK generation. It has a typical drift specification of 20ppm/°C. The oscillator frequency can be linearly swept over a 2000:1 frequency range with an external control voltage, while maintaining low distortion.

**ORDERING INFORMATION**

Part No.	Package	Operating Temperature Range
MC2206M	16 Lead 300 Mil CDIP	-55°C to +125°C
MC2206P	16 Lead 300 Mil PDIP	-40°C to +85°C
MC2206CP	16 Lead 300 Mil PDIP	0°C to +70°C
MC2206D	16 Lead 300 Mil JEDEC SOIC	0°C to +70°C

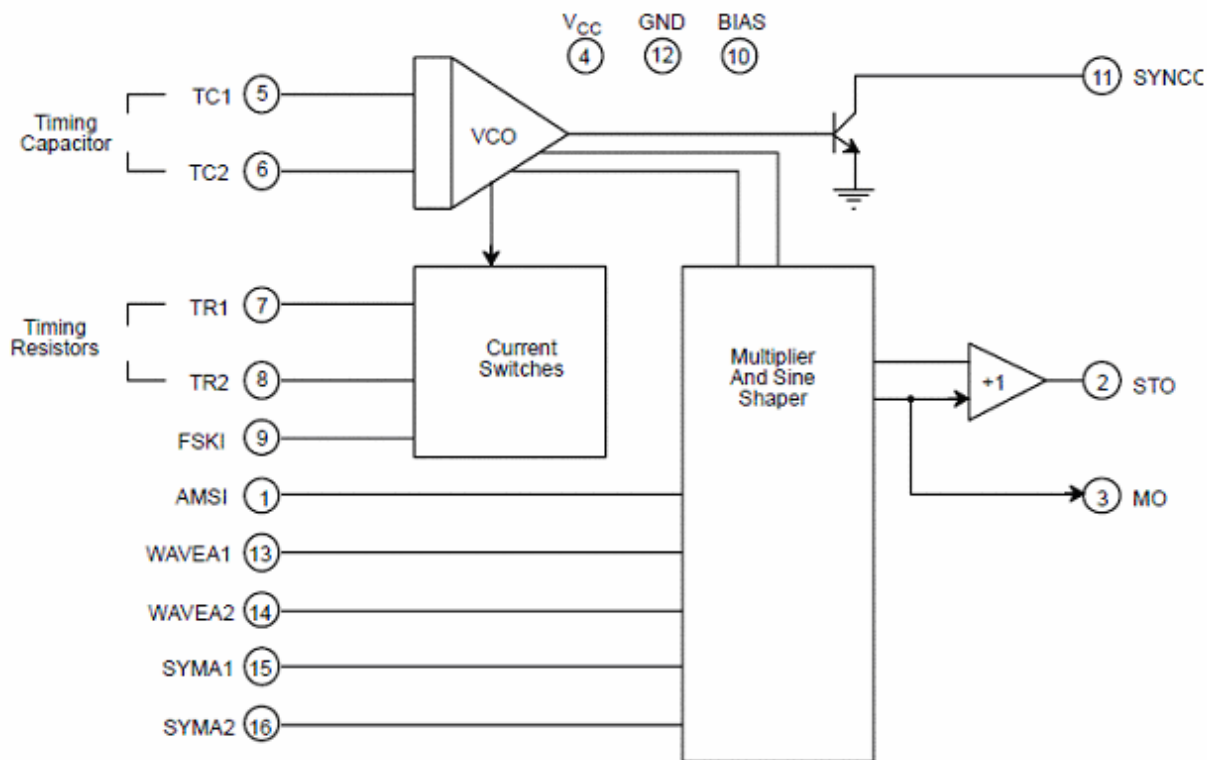
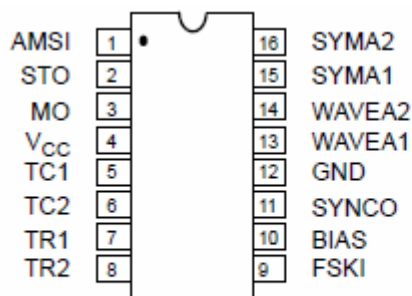
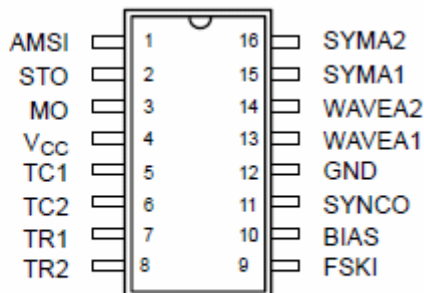

Figure 1. MC2206 Block Diagram

# MC2206



16 Lead PDIP, CDIP (0.300")



16 Lead SOIC (Jedec, 0.300")

**PIN DESCRIPTION**

Pin #	Symbol	Type	Description
1	AMSI	I	Amplitude Modulating Signal Input.
2	STO	O	Sine or Triangle Wave Output.
3	MO	O	Multiplier Output.
4	V <sub>CC</sub>		Positive Power Supply.
5	TC1	I	Timing Capacitor Input.
6	TC2	I	Timing Capacitor Input.
7	TR1	O	Timing Resistor 1 Output.
8	TR2	O	Timing Resistor 2 Output.
9	FSKI	I	Frequency Shift Keying Input.
10	BIAS	O	Internal Voltage Reference.
11	SYNCO	O	Sync Output. This output is a open collector and needs a pull up resistor to V <sub>CC</sub> .
12	GND		Ground pin.
13	WAVEA1	I	Wave Form Adjust Input 1.
14	WAVEA2	I	Wave Form Adjust Input 2.
15	SYMA1	I	Wave Symetry Adjust 1.
16	SYMA2	I	Wave Symetry Adjust 2.

# MC2206

## DC ELECTRICAL CHARACTERISTICS

Test Conditions: Test Circuit of Figure 2  $V_{CC} = 12V$ ,  $T_A = 25^{\circ}C$ ,  $C = 0.01_F$ ,  $R_1 = 100k_{\Omega}$ ,  $R_2 = 10k_{\Omega}$ ,  $R_3 = 25k_{\Omega}$   
 Unless Otherwise Specified.  $S_1$  open for triangle, closed for sine wave.

Parameters	MC2206MP			MC2206CP/D			Units	Conditions
	Min.	Typ.	Max.	Min.	Typ.	Max.		
<b>General Characteristics</b>								
Single Supply Voltage	10		26	10		26	V	
Split-Supply Voltage	$\pm 5$		$\pm 13$	$\pm 5$		$\pm 13$	V	
Supply Current		12	17		14	20	mA	$R_1 \geq 10k_{\Omega}$
<b>Oscillator Section</b>								
Max. Operating Frequency	0.5	1		0.5	1		MHz	$C = 1000pF$ , $R_1 = 1k_{\Omega}$
Lowest Practical Frequency		0.01			0.01		Hz	$C = 50\mu F$ , $R_1 = 2M_{\Omega}$
Frequency Accuracy		$\pm 1$	$\pm 4$		$\pm 2$		% of $f_0$	$f_0 = 1/R_1C$
Temperature Stability Frequency		$\pm 10$	$\pm 50$		$\pm 20$		ppm/ $^{\circ}C$	$0^{\circ}C \leq T_A \leq 70^{\circ}C$ $R_1 = R_2 = 20k_{\Omega}$
Sine Wave Amplitude Stability <sup>2</sup>		4800			4800		ppm/ $^{\circ}C$	
Supply Sensitivity		0.01	0.1		0.01		%/V	$V_{LOW} = 10V$ , $V_{HIGH} = 20V$ , $R_1 = R_2 = 20k_{\Omega}$
Sweep Range	1000:1	2000:1			2000:1		$f_H = f_L$	$f_H @ R_1 = 1k_{\Omega}$ $f_L @ R_1 = 2M_{\Omega}$
<b>Sweep Linearity</b>								
10:1 Sweep		2			2		%	$f_L = 1kHz$ , $f_H = 10kHz$
1000:1 Sweep		8			8		%	$f_L = 100Hz$ , $f_H = 100kHz$
FM Distortion		0.1			0.1		%	$\pm 10\%$ Deviation
<b>Recommended Timing Components</b>								
Timing Capacitor: C	0.001		100	0.001		100	$\mu F$	Figure 5
Timing Resistors: $R_1$ & $R_2$	1		2000	1		2000	k $\Omega$	
<b>Triangle Sine Wave Output<sup>1</sup></b>								
Figure 3								
Triangle Amplitude		160			160		mV/k $\Omega$	Figure 2, $S_1$ Open
Sine Wave Amplitude	40	60	80		60		mV/k $\Omega$	Figure 2, $S_1$ Closed
Max. Output Swing		6			6		V <sub>p-p</sub>	
Output Impedance		600			600		$\Omega$	
Triangle Linearity		1			1		%	
Amplitude Stability		0.5			0.5		dB	For 1000:1 Sweep
<b>Sine Wave Distortion</b>								
Without Adjustment		2.5			2.5		%	$R_1 = 30k_{\Omega}$
With Adjustment		0.4	1.0		0.5	1.5	%	See Figure 7 and Figure 8

### Notes

1 Output amplitude is directly proportional to the resistance,  $R_3$ , on Pin 3. See Figure 3.

2 For maximum amplitude stability,  $R_3$  should be a positive temperature coefficient resistor.

**Bold face parameters** are covered by production test and guaranteed over operating temperature range.

# MC2206

## DC ELECTRICAL CHARACTERISTICS (CONT'D)

Parameters	MC2206MP			MC2206CP/D			Units	Conditions
	Min.	Typ.	Max.	Min.	Typ.	Max.		
<b>Amplitude Modulation</b>								
Input Impedance	50	100		50	100		kΩ	
Modulation Range		100			100		%	
Carrier Suppression		55			55		dB	
Linearity		2			2		%	For 95% modulation
<b>Square-Wave Output</b>								
Amplitude		12			12		Vp-p	Measured at Pin 11.
Rise Time		250			250		ns	C <sub>L</sub> = 10pF
Fall Time		50			50		ns	C <sub>L</sub> = 10pF
Saturation Voltage		0.2	0.4		0.2	0.6	V	I <sub>L</sub> = 2mA
Leakage Current		0.1	20		0.1	100	μA	V <sub>CC</sub> = 26V
FSK Keying Level (Pin 9)	0.8	1.4	2.4	0.8	1.4	2.4	V	See section on circuit controls
Reference Bypass Voltage	2.9	3.1	3.3	2.5	3	3.5	V	Measured at Pin 10.

### Notes

1 Output amplitude is directly proportional to the resistance, R3, on Pin 3. See Figure 3.

2 For maximum amplitude stability, R3 should be a positive temperature coefficient resistor.

**Bold face parameters** are covered by production test and guaranteed over operating temperature range.

Specifications are subject to change without notice

### ABSOLUTE MAXIMUM RATINGS

Power Supply . . . . . 26V

Power Dissipation . . . . . 750mW

Derate Above 25°C . . . . . 5mW/°C

Total Timing Current . . . . . 6mA

Storage Temperature . . . . . -65°C to +150°C

### SYSTEM DESCRIPTION

The MC2206 is comprised of four functional blocks; a voltage-controlled oscillator (VCO), an analog multiplier and sine-shaper; a unity gain buffer amplifier; and a set of current switches.

The VCO produces an output frequency proportional to an input current, which is set by a resistor from the timing terminals to ground. With two timing pins, two discrete output frequencies can be independently produced for FSK generation applications by using the FSK input control pin. This input controls the current switches which select one of the timing resistor currents, and routes it to the VCO.

# MC2206

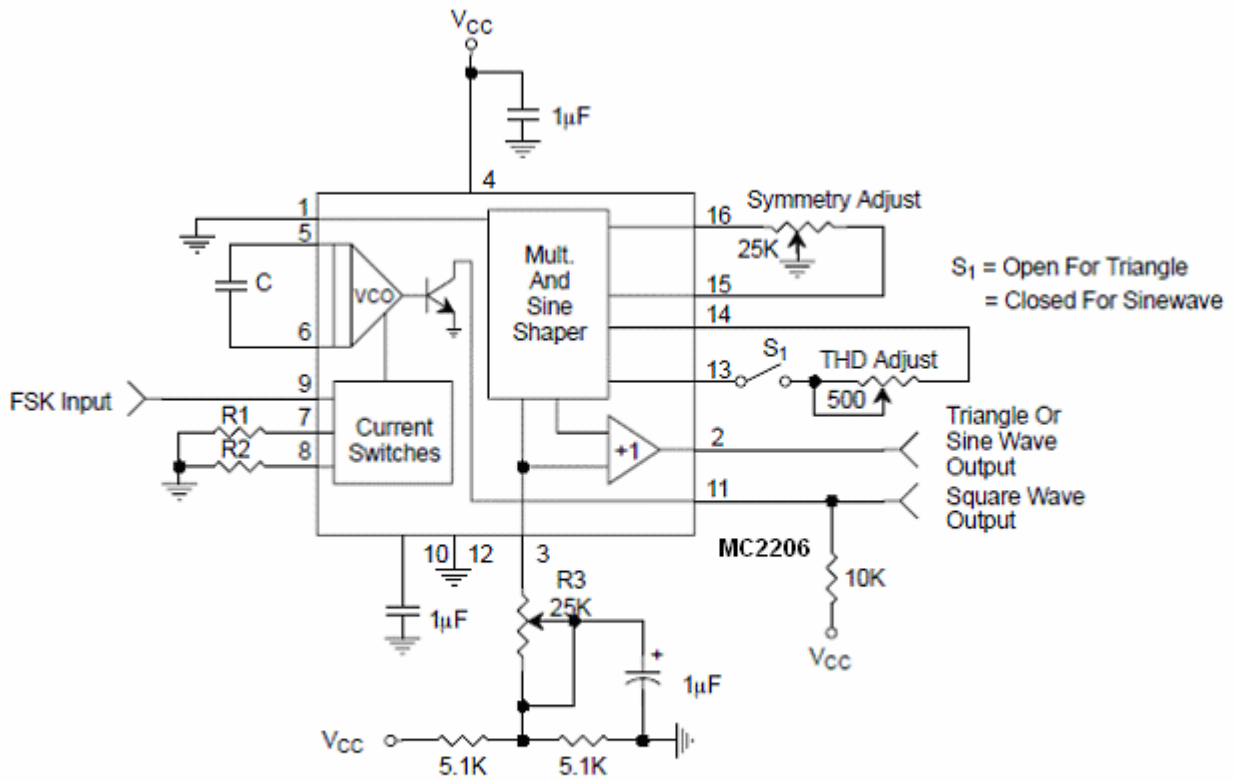

Figure 2. Basic Test Circuit

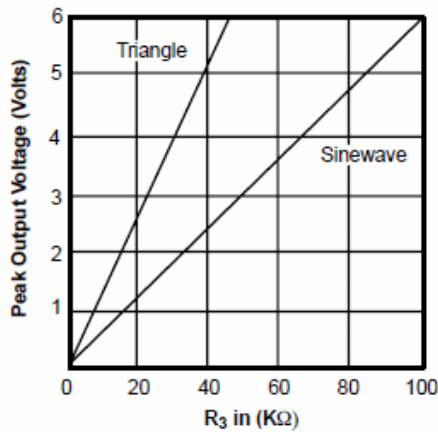

Figure 3. Output Amplitude as a Function of the Resistor, R3, at Pin 3

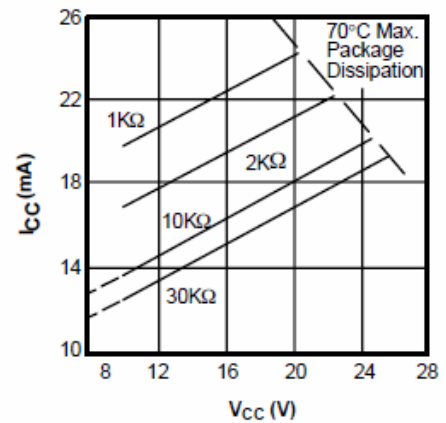

Figure 4. Supply Current vs Supply Voltage, Timing, R

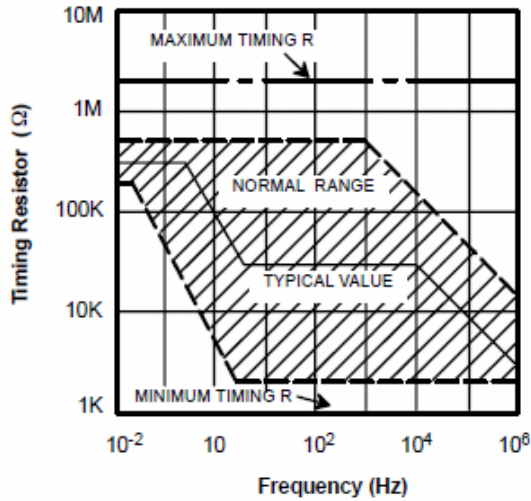

Figure 5. R versus Oscillation Frequency.

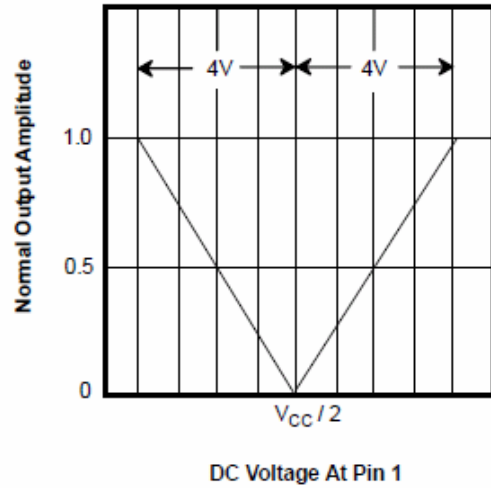

Figure 6. Normalized Output Amplitude versus DC Bias at AM Input (Pin 1)

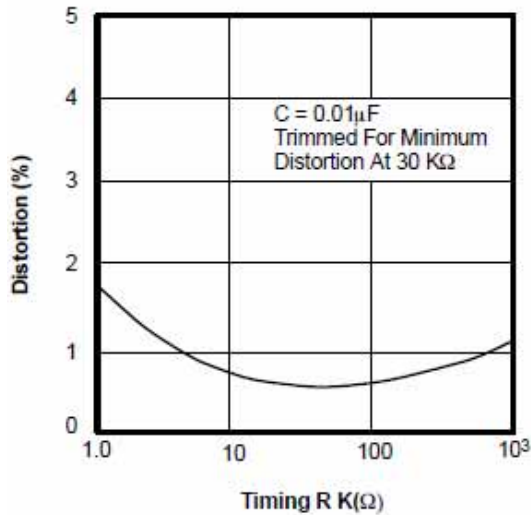

Figure 7. Trimmed Distortion versus Timing Resistor.

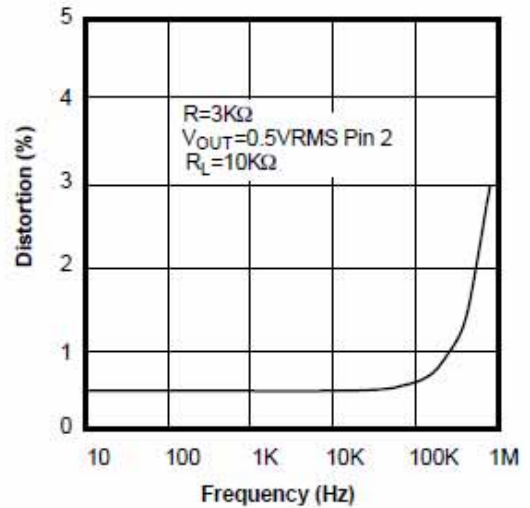

Figure 8. Sine Wave Distortion versus Operating Frequency with Timing Capacitors Varied.

# MC2206

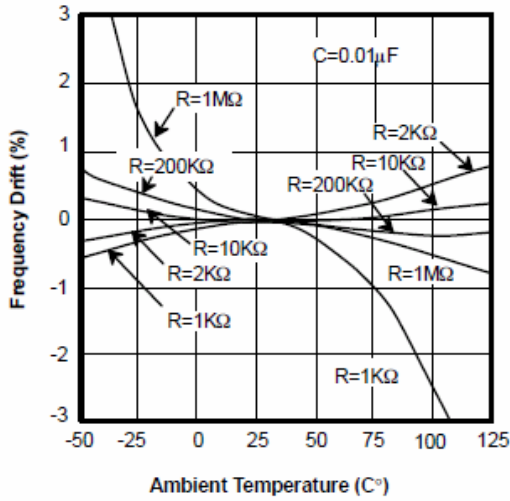

Figure 9. Frequency Drift versus Temperature.

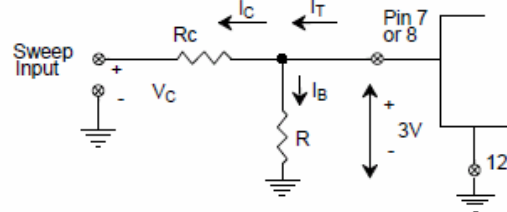

Figure 10. Circuit Connection for Frequency Sweep.

Figure 9. Frequency Drift versus Temperature.

Figure 10. Circuit Connection for Frequency Sweep.

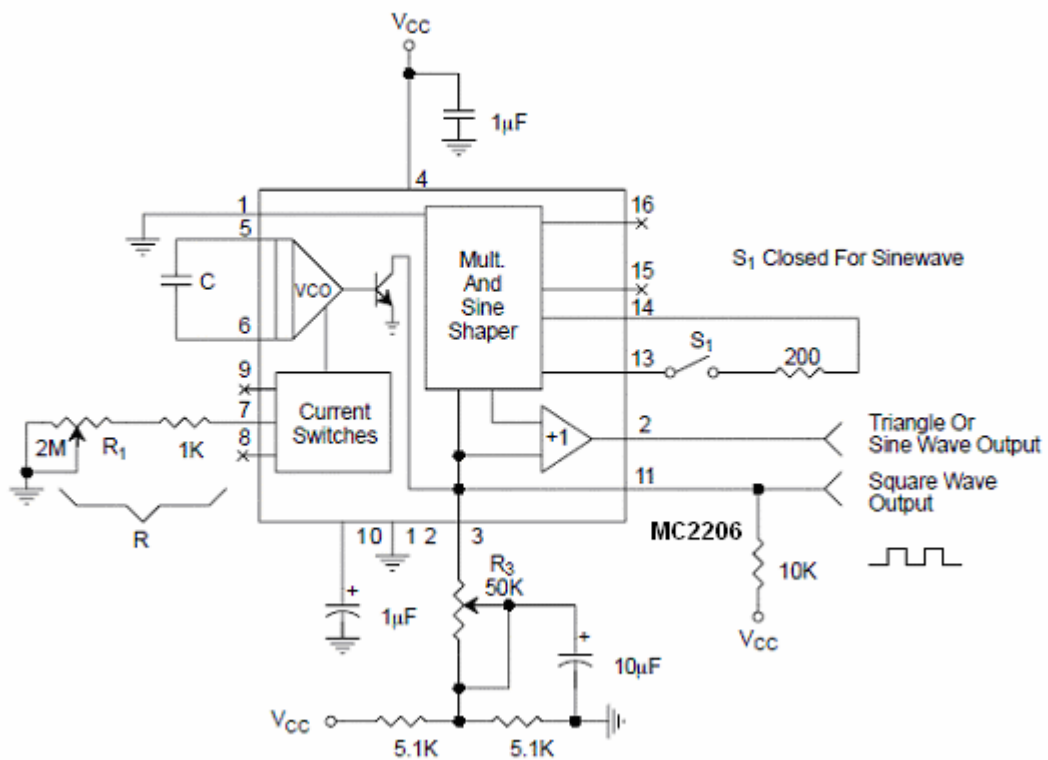
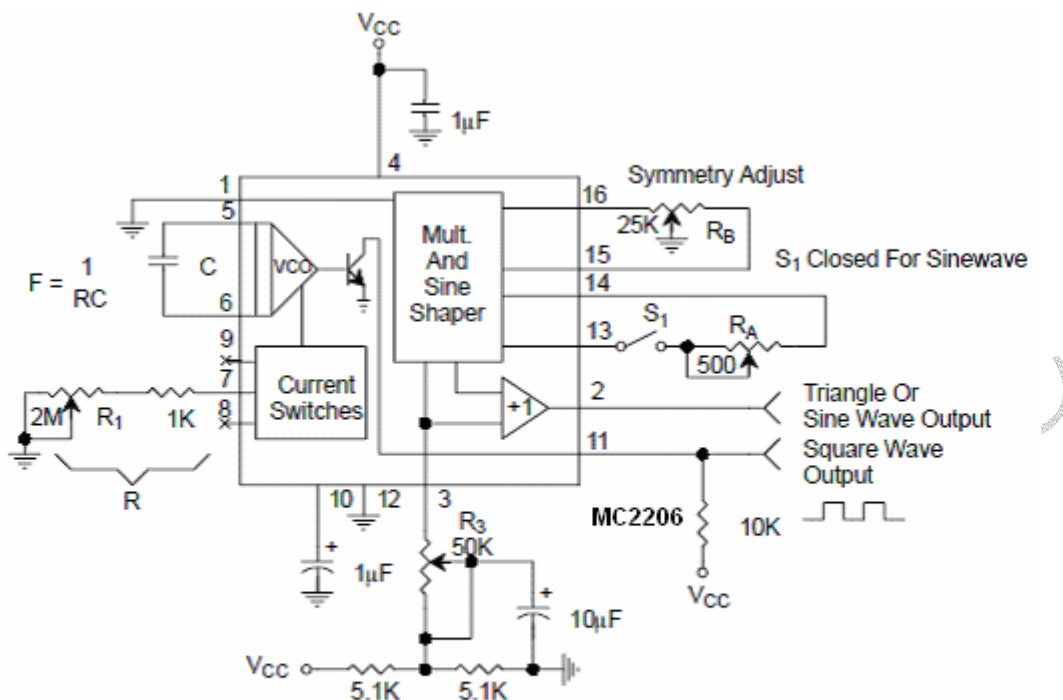
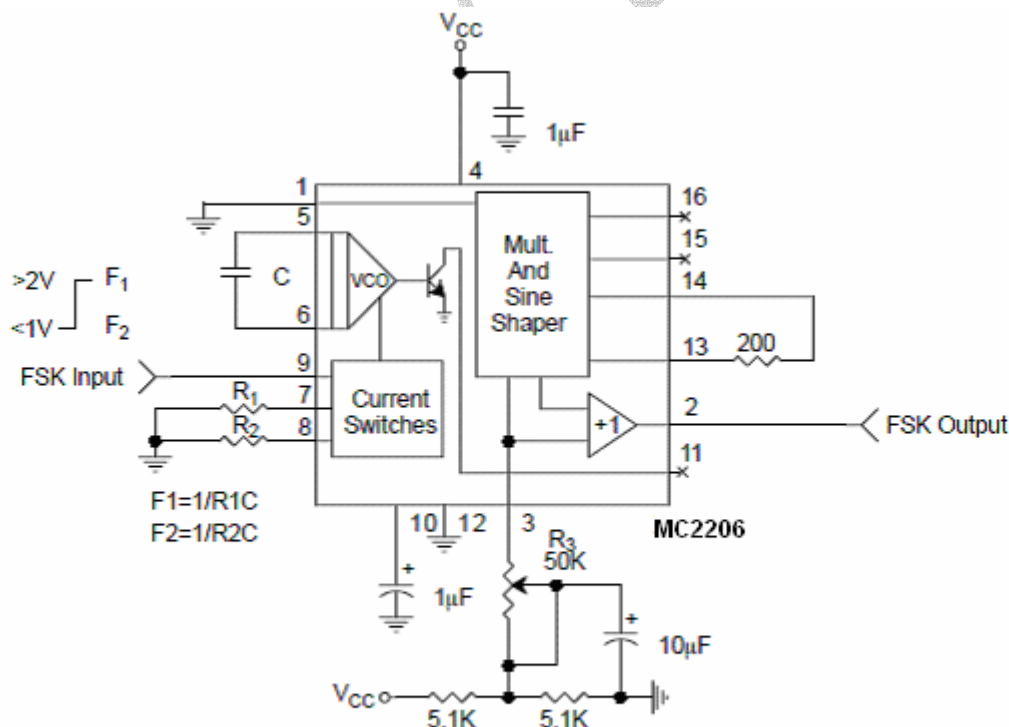

Figure 11. Circuit for Sine Wave Generation without External Adjustment. (See Figure 3 for Choice of R3)

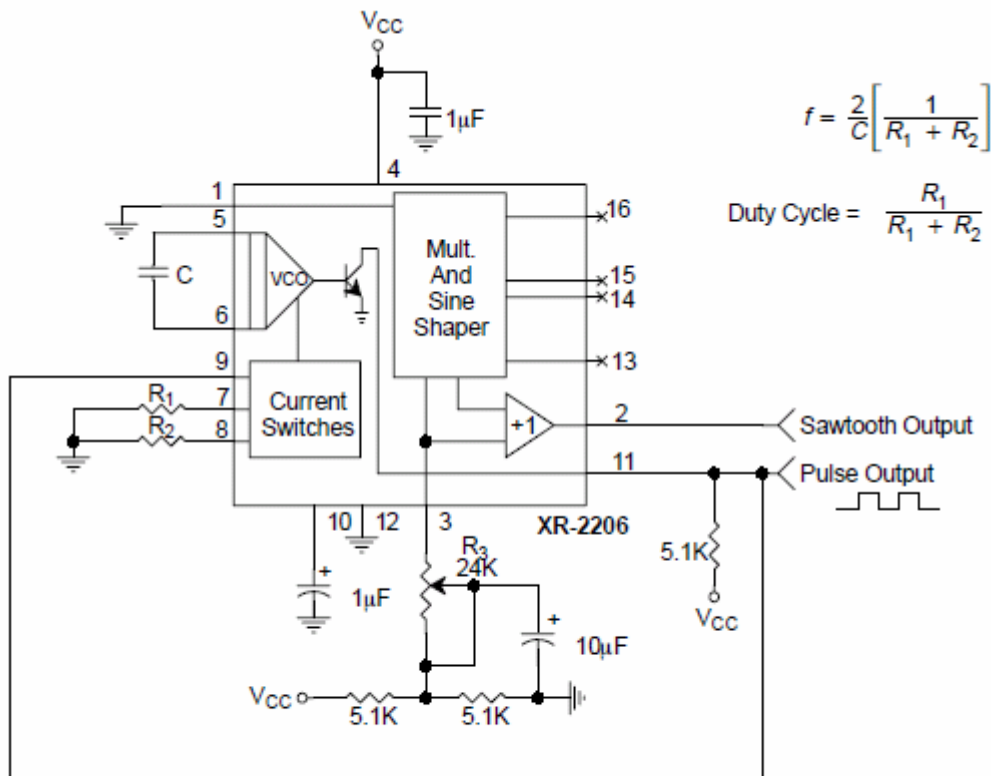



**Figure 12. Circuit for Sine Wave Generation with Minimum Harmonic Distortion.**  
 ( $R_3$  Determines Output Swing - See Figure 3)



**Figure 13. Sinusoidal FSK Generator**



**Figure 14. Circuit for Pulse and Ramp Generation.**

### Frequency-Shift Keying

The MC2206 can be operated with two separate timing resistors, R1 and R2, connected to the timing Pin 7 and 8, respectively, as shown in Figure 13. Depending on the polarity of the logic signal at Pin 9, either one or the other of these timing resistors is activated. If Pin 9 is open-circuited or connected to a bias voltage  $_2V$ , only R1 is activated. Similarly, if the voltage level at Pin 9 is  $_1V$ , only R2 is activated. Thus, the output frequency can be keyed between two levels.  $f_1$  and  $f_2$ , as:

$$f_1 = 1/R_1C \text{ and } f_2 = 1/R_2C$$

For split-supply operation, the keying voltage at Pin 9 is referenced to  $V_-$ .

### Output DC Level Control

The dc level at the output (Pin 2) is approximately the same as the dc bias at Pin 3. In Figure 11, Figure 12 and Figure 13, Pin 3 is biased midway between  $V_+$  and ground, to give an output dc level of  $_V+/2$ .

## APPLICATIONS INFORMATION

### Sine Wave Generation

#### Without External Adjustment

Figure 11 shows the circuit connection for generating a sinusoidal output from the MC2206. The potentiometer, R1 at Pin 7, provides the desired frequency tuning. The maximum output swing is greater than  $V+/2$ , and the typical distortion (THD) is  $< 2.5\%$ . If lower sine wave distortion is desired, additional adjustments can be provided as described in the following section.

The circuit of Figure 11 can be converted to split-supply operation, simply by replacing all ground connections with  $V_-$ . For split-supply operation, R3 can be directly connected to ground.

**With External Adjustment:**

The harmonic content of sinusoidal output can be reduced to -0.5% by additional adjustments as shown in Figure 12. The potentiometer, RA, adjusts the sine-shaping resistor, and RB provides the fine adjustment for the waveform symmetry. The adjustment procedure is as follows:

1. Set RB at midpoint and adjust RA for minimum distortion.
2. With RA set as above, adjust RB to further reduce distortion.

**Triangle Wave Generation**

The circuits of Figure 11 and Figure 12 can be converted to triangle wave generation, by simply open-circuiting Pin 13 and 14 (i.e., S1 open). Amplitude of the triangle is approximately twice the sine wave output.

**FSK Generation**

Figure 13 shows the circuit connection for sinusoidal FSK signal operation. Mark and space frequencies can be independently adjusted by the choice of timing resistors, R1 and R2; the output is phase-continuous during transitions. The keying signal is applied to Pin 9. The circuit can be converted to split-supply operation by simply replacing ground with V-.

**Pulse and Ramp Generation**

Figure 14 shows the circuit for pulse and ramp waveform generation. In this mode of operation, the FSK keying terminal (Pin 9) is shorted to the square-wave output (Pin 11), and the circuit automatically frequency-shift keys itself between two separate frequencies during the positive-going and negative-going output waveforms. The pulse width and duty cycle can be adjusted from 1% to 99% by the choice of R1 and R2. The values of R1 and R2 should be in the range of 1k<sub>Ω</sub> to 2M<sub>Ω</sub>.

**PRINCIPLES OF OPERATION****Description of Controls****Frequency of Operation:**

The frequency of oscillation,  $f_0$ , is determined by the external timing capacitor, C, across Pin 5 and 6, and by the timing resistor, R, connected to either Pin 7 or 8. The frequency is given as:

$$f_0 = \frac{1}{RC} \text{ Hz}$$

and can be adjusted by varying either R or C. The recommended values of R, for a given frequency range, as shown in Figure 5. Temperature stability is optimum for 4k<sub>Ω</sub> < R < 200k<sub>Ω</sub>. Recommended values of C are from 1000pF to 100<sub>nF</sub>.

**Frequency Sweep and Modulation:**

Frequency of oscillation is proportional to the total timing current, IT, drawn from Pin 7 or 8:

$$f = \frac{320I_T(\text{mA})}{C(\mu\text{F})} \text{ Hz}$$

Timing terminals (Pin 7 or 8) are low-impedance points, and are internally biased at +3V, with respect to Pin 12. Frequency varies linearly with IT, over a wide range of current values, from 1<sub>μA</sub> to 3mA. The frequency can be controlled by applying a control voltage, Vc, to the activated timing pin as shown in Figure 10. The frequency of oscillation is related to Vc as:

$$f = \frac{1}{RC} \left( 1 + \frac{R}{R_c} \left( 1 - \frac{V_c}{3} \right) \right) \text{ Hz}$$

where Vcis in volts. The voltage-to-frequency conversion gain, K, is given as:

$$K = \frac{\partial f}{\partial V_c} = -\frac{0.32}{R_c C} \text{ Hz/V}$$

**CAUTION:** For safety operation of the circuit, IT should be limited to <sub>μ</sub> 3mA.

**Output Amplitude:**

Maximum output amplitude is inversely proportional to the external resistor, R3, connected to Pin 3 (see Figure 3). For sine wave output, amplitude is approximately 60mV peak per k\_ of R3; for triangle, the peak amplitude is approximately 160mV peak per k\_ of R3. Thus, for example, R3 = 50k\_ would produce approximately 13V sinusoidal output amplitude.

**Amplitude Modulation:**

Output amplitude can be modulated by applying a dc bias and a modulating signal to Pin 1. The internal impedance at Pin 1 is approximately 100k\_. Output amplitude varies linearly with the applied voltage at Pin 1, for values of dc bias at this pin, within 14 volts of VCC/2 as shown in Figure 6. As this bias level approaches VCC/2, the phase of the output signal is reversed, and the amplitude goes through zero. This property is suitable for phase-shift keying and suppressed-carrier AM generation. Total dynamic range of amplitude modulation is approximately 55dB.

**CAUTION:** AM control must be used in conjunction with a well-regulated supply, since the output amplitude now becomes a function of VCC.

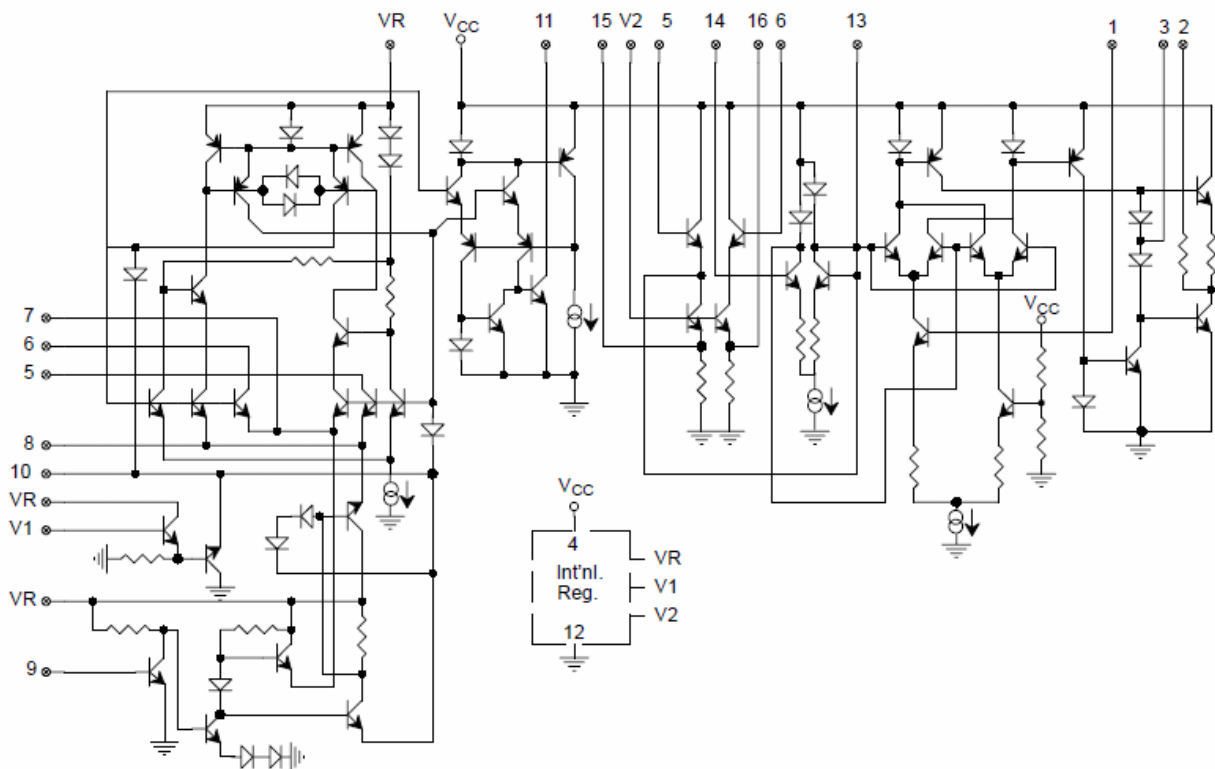
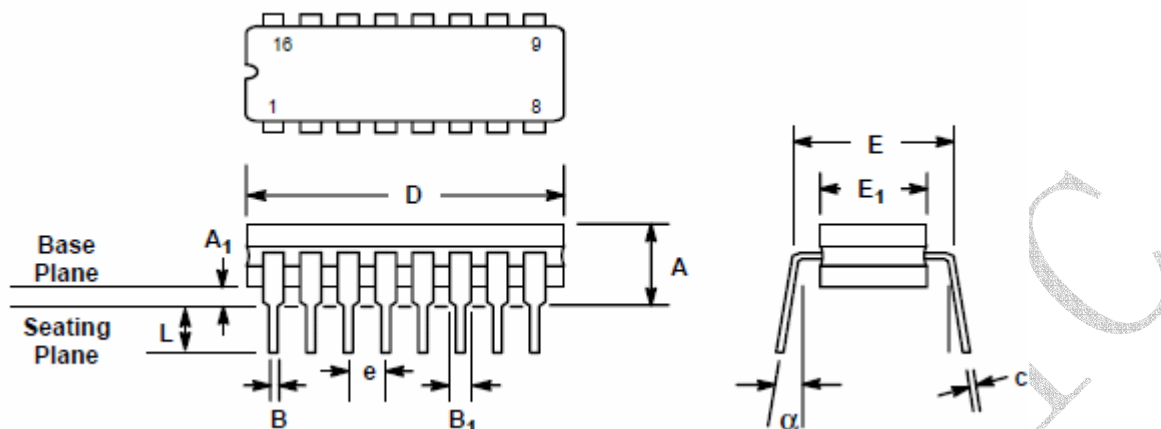

Figure 15. Equivalent Schematic Diagram

# MC2206

## 16 LEAD CERAMIC DUAL-IN-LINE (300 MIL CDIP) Rev. 1.00



SYMBOL	INCHES		MILLIMETERS	
	MIN	MAX	MIN	MAX
A	0.100	0.200	2.54	5.08
A <sub>1</sub>	0.015	0.060	0.38	1.52
B	0.014	0.026	0.36	0.66
B <sub>1</sub>	0.045	0.065	1.14	1.65
c	0.008	0.018	0.20	0.46
D	0.740	0.840	18.80	21.34
E <sub>1</sub>	0.250	0.310	6.35	7.87
E	0.300 BSC		7.62 BSC	
e	0.100 BSC		2.54 BSC	
L	0.125	0.200	3.18	5.08
α	0°	15°	0°	15°

Note: The control dimension is the inch column

# MC2206

## 16 LEAD PLASTIC DUAL-IN-LINE (300 MIL PDIP) Rev. 1.00

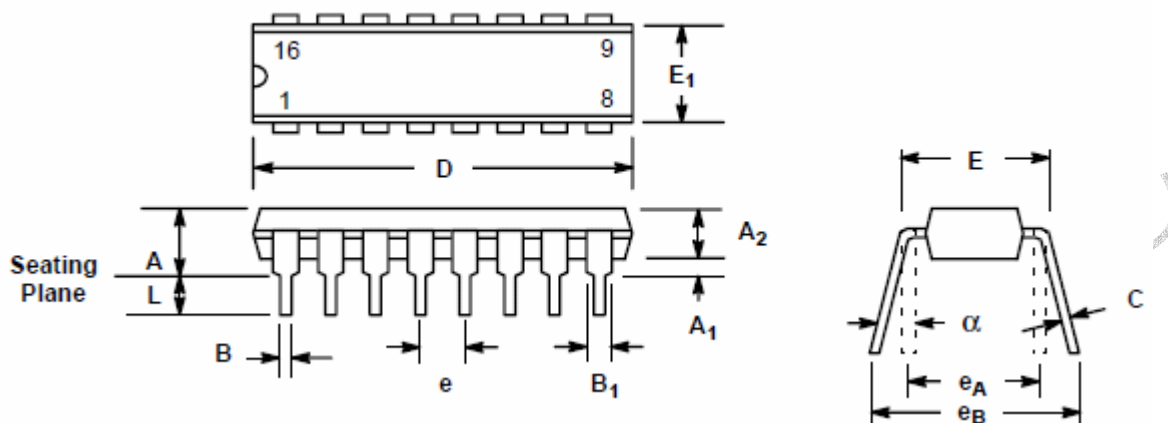

SYMBOL	INCHES		MILLIMETERS	
	MIN	MAX	MIN	MAX
A	0.145	0.210	3.68	5.33
A <sub>1</sub>	0.015	0.070	0.38	1.78
A <sub>2</sub>	0.115	0.195	2.92	4.95
B	0.014	0.024	0.36	0.56
B <sub>1</sub>	0.030	0.070	0.76	1.78
C	0.008	0.014	0.20	0.38
D	0.745	0.840	18.92	21.34
E	0.300	0.325	7.62	8.26
E <sub>1</sub>	0.240	0.280	6.10	7.11
e	0.100 BSC		2.54 BSC	
e <sub>A</sub>	0.300 BSC		7.62 BSC	
e <sub>B</sub>	0.310	0.430	7.87	10.92
L	0.115	0.160	2.92	4.06
α	0°	15°	0°	15°

Note: The control dimension is the inch column

# MC2206

## 16 LEAD SMALL OUTLINE (300 MIL JEDEC SOIC)

Rev. 1.00

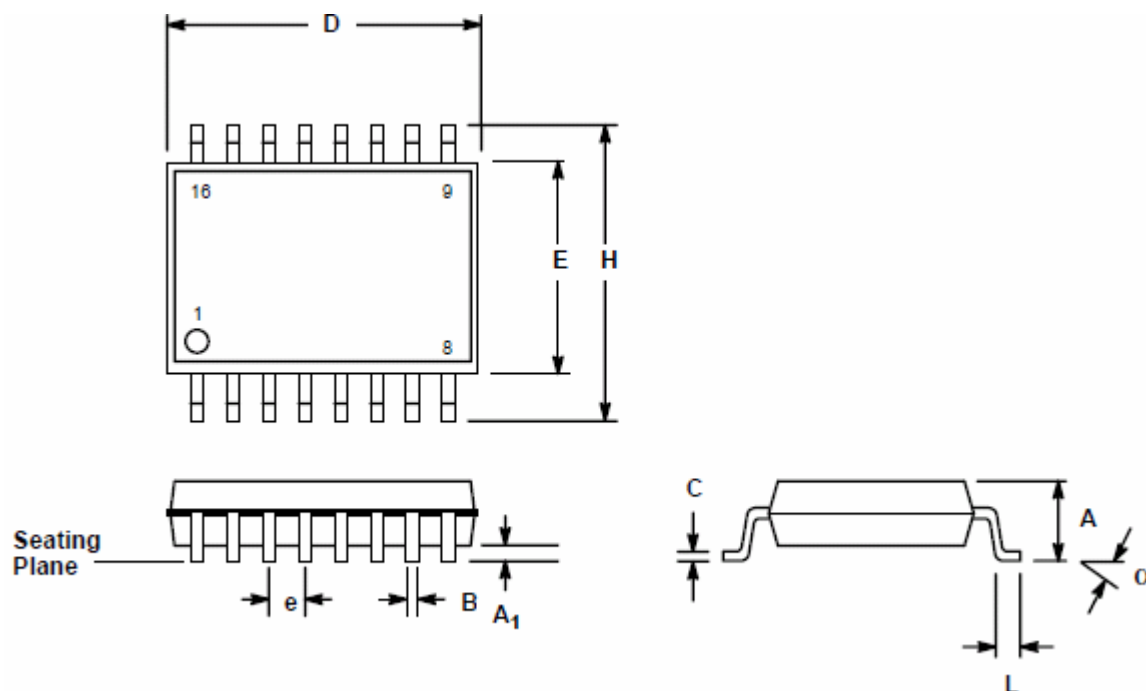

SYMBOL	INCHES		MILLIMETERS	
	MIN	MAX	MIN	MAX
A	0.093	0.104	2.35	2.65
A <sub>1</sub>	0.004	0.012	0.10	0.30
B	0.013	0.020	0.33	0.51
C	0.009	0.013	0.23	0.32
D	0.398	0.413	10.10	10.50
E	0.291	0.299	7.40	7.60
e	0.050 BSC		1.27 BSC	
H	0.394	0.419	10.00	10.65
L	0.016	0.050	0.40	1.27
α	0°	8°	0°	8°

Note: The control dimension is the millimeter column